

IMAGENEX MODEL 965A MULTIBEAM IMAGING SONAR

APPLICATIONS:

- ROV, AUV, & UUV
- Offshore Oil & Gas
- Sunken Timber Recovery
- Diving Support
- Surveying
- Search & Recovery
- Inspection
- Underwater Archaeology
- Scientific Research
- Harbour Surveillance

FEATURES:

- Enhanced vertical scan capabilities
- High speed
- Ethernet (10/100 Mbps)
- Programmable
- Simple set-up and installation
- 1 m to 100 m range scales
- Integrated Video Capture and Display
- User programmable IP address
- Raw data available to user

The Imagenex Model 965A is an advanced, high-speed, high-resolution, multibeam imaging sonar system that has been designed to provide simple, reliable, and accurate representation of underwater images.

The system consists of an underwater sonar head connected by Ethernet to a Windows™ based computer.



HARDWARE SPECIFICATIONS:	
FREQUENCY	675 kHz
TRANSDUCER BEAM WIDTH (nominal)	Receive: 120° (horizontal) x 20° (vertical) Transmit: 120° (horizontal) x 20° (vertical)
EFFECTIVE HORIZONTAL BEAM WIDTH	1.5°
BEAMS*	120, 240, 480
RANGE RESOLUTION	0.2% of range
MIN. DETECTABLE RANGE	0.5 m
MAX. OPERATING DEPTH	1000 m and 2000 m available
FRAME RATE	Up to 40 fps
INTERFACE TO PC	Standard: 10/100 Mbps Ethernet (10 BASE-T or 100 BASE-TX) using TCP/IP
MAX. CABLE LENGTH	Standard: 100 m on CAT5e
CONNECTOR	End mounted, 8 conductor, wet mateable (Subconn MCBH8M-AS)
POWER SUPPLY	22 – 32 VDC at less than 25 Watts
DIMENSIONS	See drawing
WEIGHT: In Air	1000 m unit: 1.5 kg (3.3 lbs) 2000 m unit: TBA
In Water	1000 m unit: 0.045 kg (0.01 lbs) 2000 m unit: TBA
MATERIALS	1000 m unit: 6061-T6 Aluminum, Epoxy, PVC, Aluminum connector 2000 m unit: Titanium, Epoxy, PVC, Titanium connector
FINISH	Anodize

*Data is acquired at full resolution every shot: processing the data for screen display on a PC can slow the system at highest number of beams. 120 beam mode is recommended for real time data acquisition. The data can then be played back at highest resolution (480 beam).

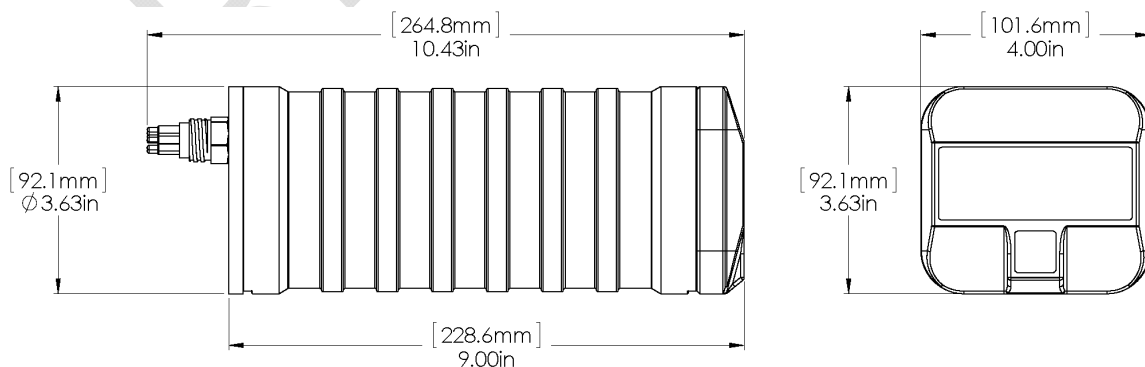

SOFTWARE SPECIFICATIONS:	Win965A.exe
WINDOWS™ OPERATING SYSTEM	Windows™ XP, Vista, 7, 8, 10
DISPLAY MODES	Sector, Linear, Perspective, Profile, Beam Test
PERSISTENCE (TRAIL)	1 – 300 seconds
RANGE SCALES	1 m - 100 m
SECTOR SIZES	30°, 60°, 90°, 120°
FILE FORMAT	(filename).IGX
RECOMMENDED MINIMUM COMPUTER REQUIREMENTS:	2 GHz Pentium 4 256 MB RAM 20 GB Hard Disk 1024 x 768 screen resolution

ORDERING INFORMATION:		
1000 m UNIT	Standard	965A-000-200
2000 m UNIT	Standard	965A-000-201
Right Angle Connector	Option	-010

Product and company names listed are trademarks or trade names of their respective companies.